

CONVERTIBLE WEATHERSTRIP

HARDTOP WEATHERSTRIP

RUBBER

the Right Way

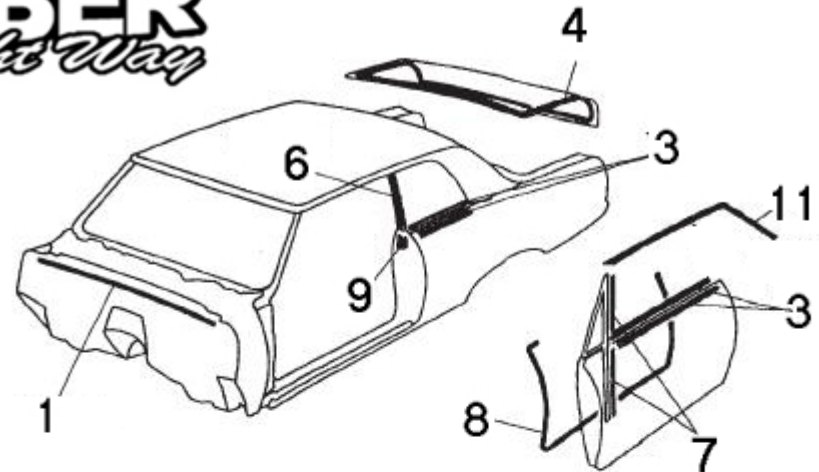
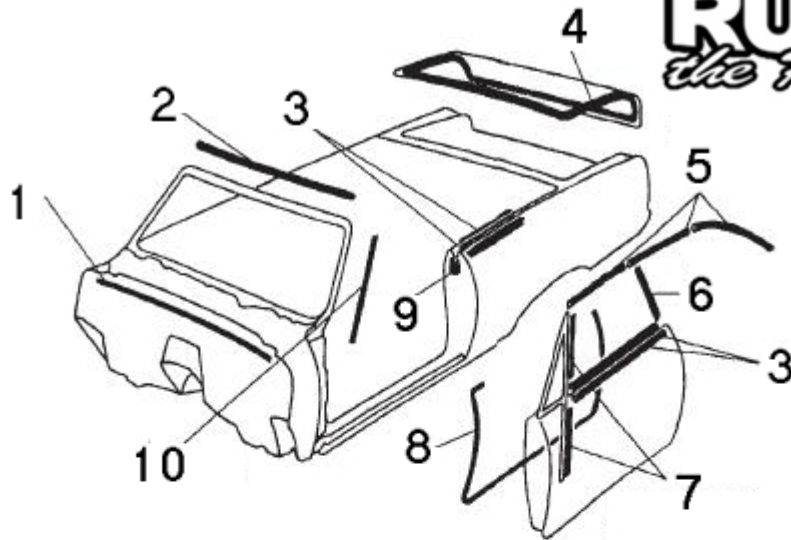

1) Hood to cowl seal - typically attaches to the top of the firewall and runs the width of the car to seal the back edge of the hood. Most vehicles require special clips to hold this seal in place.

2) Header / bow seal - this seals the front section of the convertible top to the top of the windshield frame.

3) Beltline seals / windowfelts / fuzzies - these are the seals that run horizontally at the base of each door or quarter glass and "sweep" the glass as it goes up and down. There is an inner & outer seal for each door & quarter glass. The inner typically attaches to the tops of the door panels. The outer are usually attached to the body trim.

4) Trunk seal - seals the trunk lid to the body. Most cars use a single seal which glues into a gutter in the body. Some older models required 2 or more separate seals, and some models have a seal on the trunk lid itself.

5) Convertible roof rail seals - these seal the sides of the convertible top to the door and quarter glass. There are typically 2-4 pieces per side. These seals will be vulcanized to a steel core with threaded studs for attaching to the convertible top frame.

6) Quarter or side window leading edge seals - on 2 door models these are the vertical seals that attach to the front side of the quarter window and seal the gap between the door and quarter glass. On 4 door hardtop models (no "post") this seal will attach to the front of the rear door glass to seal the vertical space between the front & rear door glass.

7) Vent window division channel / flocked channel seal - this is the channel on the back side of the vent window frame that guides the front edge of the door glass as it goes up and down. Some models have a flexible rubber channel that can be removed and replaced. Some models have a metal channel with a flocked liner that can be replaced.

8) Door seals - these seal the perimeter of the door to the body. 2 & 4 door hardtops & convertibles usually have molded ends. 2 & 4 door "post" sedans with framed door glass usually have one continuous seal.

9) Lock pillar filler or U jamb seal - on 2 door models these can be found in the door jamb at the base of the quarter windows on the body. These are also used on 4 door hardtops and are generally on the door.

10) Hinge pillar seals - these attach to the sides of the windshield frame and seal the windshield frame to the door glass or vent window frame.

11) Hardtop roof rail seals - these attach to the body along the roof line and seal the tops of the side glass to the body. They generally start on the hinge / A pillar and go up and over the side glass.